

# DSHT DIAPHRAGM SEAL HEAVY THREADED WELDED



## MAIN FEATURES

- Economical and light weigh
- All welded construction
- Laser welded diaphragm

## SUGGESTED APPLICATIONS

- Separation systems
- Isolation applications
- Viscous & corrosive media
- High-pressure applications
- High vibration application

## BASIC DESCRIPTION

- Storage Temperature : -40...+65°C
- Service Temperature : 370°C max.
- Weld Joints: Laser welding for Diaphragm



## DIAPHRAGM SEAL HEAVY THREADED WELDED

### STANDARD DETAILS

- Range type : -1...0 bar & 0...2.5 bar / 4...70 bar / 100...250 bar / 280...600 bar
- Chamber material : AISI 316 SS
- Diaphragm : AISI 316L SS
- Instrument connection : 1/2" NPT (F)
- Diaphragm Filling fluid : Silicon DC 200 (-40...205°C)
- Process connection : 1/2" NPT (M)
- Assembly : Direct
- Capillary : Optional
- Armour : Optional
- Remote mounting length : Optional

## DIMENSIONAL DRAWING

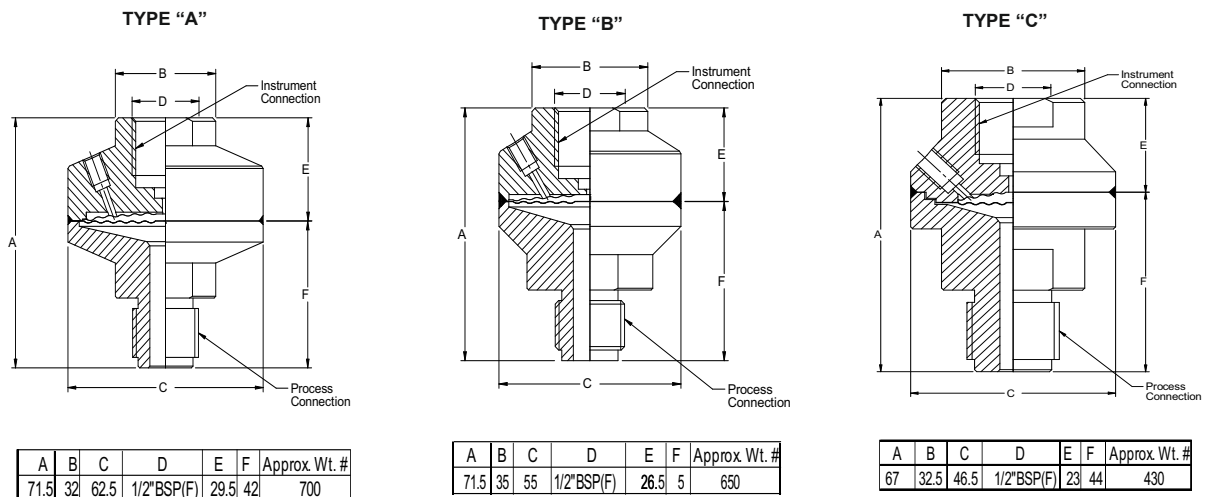

All dimensions are in mm.

## MODEL CODING

MODEL	-	TOP CHAMBER	DIAPHRAGM	BOTTOM CHAMBER	/	INSTRUMENT CONNECTION	PROCESS CONNECTION	/	Diaphragm Filling Fluid	/
DSHT = DIAPHRAGM SEAL HEAVY THREADED WELDED		S04 = SS 304 S16 = SS 316	S6L = SS 316L M40 = Monel 400 H76 = Hastelloy C-276	S16 = SS 316 S6L = SS 316L M40 = Monel 400 H76 = Hastelloy C-276 N62 = Inconel 625 TT6 = Titanium PVC = PVC PPY = Polypropylene PTFE = PTFE		F4N = ½" NPT (F) F4B = ½" BSP (F) F2N = ¼" NPT (F) F2B = ¼" BSP (F)	M2N = ¼" NPT (M) M2B = ¼" BSP (M) M4N = ½" NPT (M) MBN = ½" BSP (M) M2M = M12 X 1.0P M4M = M20 X 1.5P M3B = ¾" BSP (M) F40 = 1.5" NPT (M)		L2 = Silicon Oil L3 = Glycerin L4 = Food Grade Oil	

CAPILLARY	CAPILLARY LENGTH	OTHER OPTIONS
C1 = No Capillary C2 = SS 316L bore + SS 304 Armour C3 = SS 316L bore + SS 316 Armour C4 = SS 316L bore + SS 304 Armour + PVC coating	1 Mtr. up to 5 Mtr. Other length on request	CB = PTFE coating on bottom chamber & diaphragm CD = PTFE Coating on diaphragm MTC2.2 = Material test certificate, 2.2 MTC3.1 = Material test certificate. 3.1

**ORDERING EXAMPLE** DSHT-S04-S6L-S16-F4N-M2N-L2-C1.CB

**QUICK ORDER DETAILS / FEEDBACKS**

.....

.....

.....

.....

.....