

722R / 732R / 742R / 752R / 762R RTD WITH HEAD ENCLOSURE WITH VARIOUS HEAD EXTENSIONS



MAIN FEATURES

Mineral insulated cable
Crimp-on-pot sealed
Spring loaded sheaths
Various extensions / connections
Exchangeable Inserts

SUGGESTED APPLICATIONS

Liquid & gaseous mediums
Power & Utilities
Water treatment plants
Furnace, Ovens & Boilers
Machineries, Plants & Tanks



RTD WITH HEAD ENCLOSURE

BASIC DESCRIPTION

Reference standard : IEC-751
Sensor type : Pt-100 [100Ω ± 0.06%]
 α value : 0.00385 ± 0.000063 z / z / °C
Range : -200°C to +650°C
Thin film : -200 to 400°C, Ceramic sensor : -50 to 650°C
Accuracy : Class A
Internal leads : Copper, mineral insulated cable with compact mass of Magnesium Oxide, brazed at element end and terminated at top of the sheath by using PTFE coated multi stranded copper wire
Termination : Pot sealed
Wire colour code : Red / Red / White + Black / Black / Yellow

PRODUCT SPECIFICATION

Sensor : Pt-100, Class A, Duplex, 3-Wire
Sensor material : SS 316
Sensor diameter : Ø6 mm
Sensor length : 300 mm

STANDARD SPECIFICATION

WITHOUT CONNECTION [CODE : 722R]

Head extension: No connection
Process connection: Not applicable

OTHER VERSIONS

WITH CONNECTION [CODE : 732R]

Head extension: Fixed connection
Head extension length: 50mm
Process connection: ½" NPT (M)

WITH CONNECTION [CODE : 742R]

Head extension: Adjustable connection
Head extension length: 50mm
Process connection: ½" NPT (M)

WITH CONNECTION [CODE : 752R]

Head extension: Nipple connection
Head extension length: 100mm
Process connection: ½" NPT (M)

WITH CONNECTION [CODE : 752R]

Head extension: Nipple-Union-Nipple connection
Head extension length: 150mm
Process connection: ½" NPT (M)

REFERENCE DRAWINGS

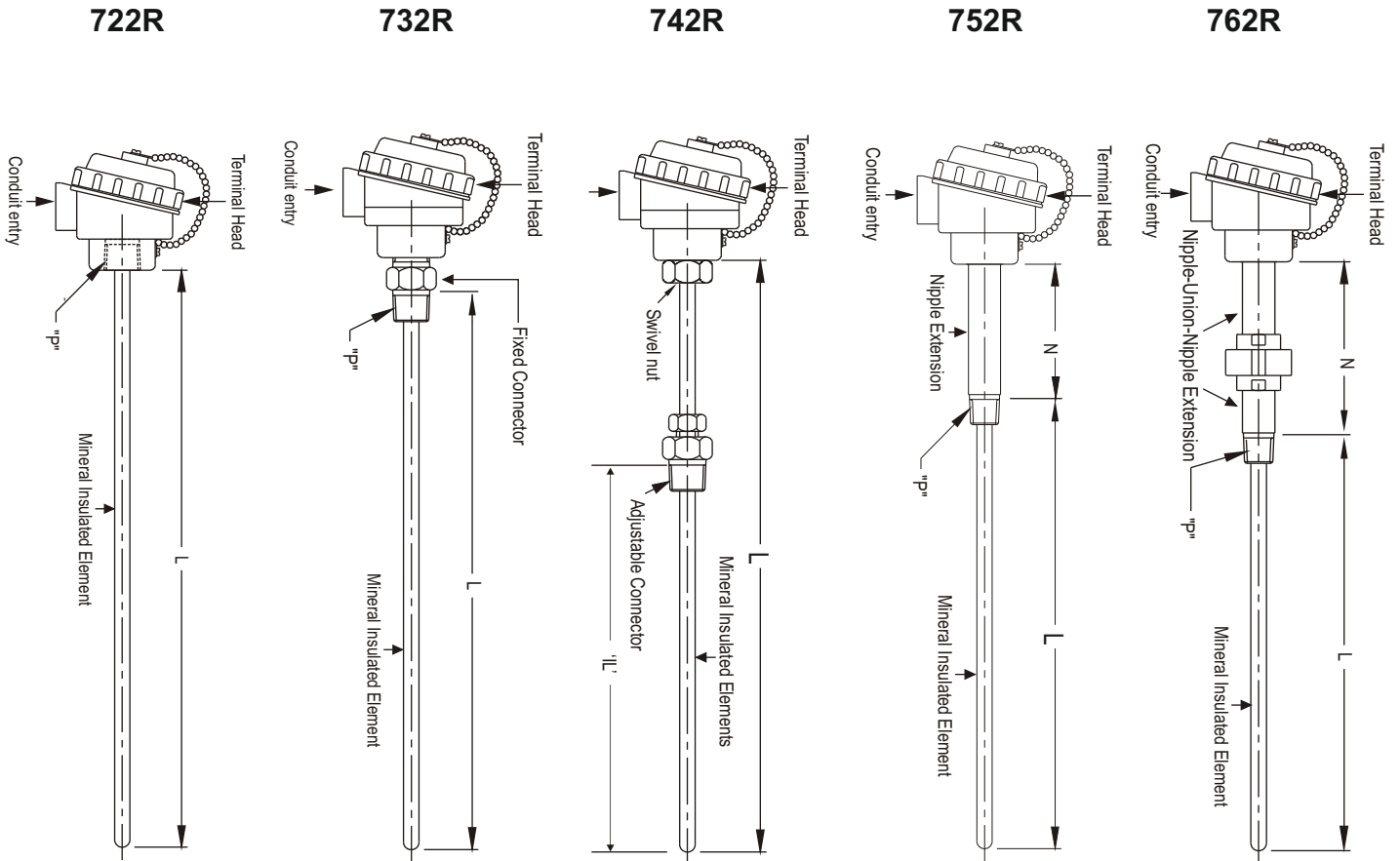

MODEL CODING

MODEL	-	ELEMENT	SHEATH MATERIAL	SHEATH DIAMETER	SHEATH LENGTH	/
722R = RTD with Head Enclosure		P1 = Pt-100, Class A, Duplex, 3-Wire	S16 = SS 316	S6 = Ø6mm	L = Insertion length	
732R = RTD with Head & Fixed Connection		P2 = Pt-100, Class A, Simplex, 4-Wire	S6L = SS 316L	S8 = Ø8mm		
742R = RTD with Head & Adjustable Connection		P3 = Pt-100, Class A, Simplex, 3-Wire		S9 = Ø10mm		
752R = RTD with Nipple Extension		P4 = Pt-100, Class A, Simplex, 2-Wire		S7 = Ø12mm		
762R = RTD with NUN Extension		P5 = Pt-500, Class A, Duplex, 3-Wire				
		P6 = Pt-500, Class A, Simplex, 4-Wire				
		P7 = Pt-1000, Class A, Duplex, 3-Wire				
		P8 = Pt-1000, Class A, Simplex, 4-wire				
		P9 = Other combinations				

ENCLOSURE PROTECTION	CONDUITS	/	HEAD EXTENSION MATERIAL	EXTENSION TYPE	EXTENSION LENGTH	/	PROCESS CONNECTION	/	OTHER OPTIONS
WP = Weather proof FP = Flame proof, IIA, IIB EP = Explosion proof IIC	1N = 1 No. x 1/2" NPT (F) 2N = 2 Nos. x 1/2" NPT (F) 1E = 1 No. x 3/4" ET (F) 2E = 2 Nos. x 3/4" ET (F) 1M = 1 No. x M20x1.5P (F) 2M = 2 Nos. x M20x1.5P (F)		S04 = SS 304 S16 = SS 316 S6L = SS 316L	XX = For 722R / 732R 742R NN = Nipple (for 752R) NU = Nipple-Union-Nipple (for 762R)	050 = 50 mm 100 = 100 mm 150 = 150 mm		M2N = 1/4" NPT (M) M2B = 1/4" BSP (M) M4N = 1/2" NPT (M) M4B = 1/2" BSP (M) M2M = M12 X 1.0P M4M = M20 X 1.5P M3B = 3/8" BSP (M)		XA = Tag plate in SS 304 XB = Tag plates in SS 316 TA = 5 - point factory calibration certificate TT = Head mount temperature transmitter, 4-20mA HH = Head mount TT, 4-20mA + HART CC = Suitable conduit connections

ORDERING EXAMPLE 742R-P1.S16.S6.150/WP.1N/S04.XX.050/M4N/XA.TA.

QUICK ORDER DETAILS / FEEDBACKS