

133B PROCESS PRESSURE GAUGES MINIATURE TYPE



MAIN FEATURES

All SS measuring system
Socket-case, direct welded
Dry / liquid filled

SUGGESTED APPLICATIONS

Liquid & gaseous mediums
Corrosive environments
Oil & Gas applications
Chemical & Petrochemical
Food & Beverages
Nuclear power plants



MINIATURE PROCESS PRESSURE GAUGES

BASIC DESCRIPTION

Sensing element : Bourdon Tube
(<100 bar : C - type , >100 bar : Helical)
Accuracy: $\pm 1.0\%$ F.S.D.
Ambient temperature: $-40...+65^{\circ}\text{C}$
Service temperature: 300°C max.
Steady pressure: Up to FS value
Fluctuating pressure: Up to 90% of FS value
Over-pressure: $1.3 \times \text{FS value} \leq 100 \text{ bar}$
 : $1.15 \times \text{FS value} \geq 100 \text{ bar}$
Weld joints: TIG argon arc welding

PRODUCT SPECIFICATION

STANDARD VERSION [CODE : 133B]

Dial size : DN40 / DN50 / DN63 / DN100
Range : $-1...0...1,000 \text{ bar}$
Mounting pattern : Direct, Bottom connection
Process connection : $1/4'' \text{ NPT (M) } / 1/4'' \text{ BSP (M)}$
Ingress protection : IP 67
Case Execution : Dry but fill-able
Case & Ring material : AISI 304 SS (Bayonet type)
Bourdon tube & Shank : AISI 316L SS (Shank welded directly to case)
Movement mechanism : AISI 304 SS
Dial : Aluminum, black graduation on white background
Pointer : Micro-zero adjustable, aluminum, black powder coated
Gaskets, Blow off disc & filling plug : Neoprene
Window : Shatterproof safety glass

LIQUID FILLED VERSION (GLYCERIN) [CODE : G]

Ambient temperature: $-20...+65^{\circ}\text{C}$
Dampening liquid : Glycerin 99.7%

LIQUID FILLED VERSION (SILICON OIL) [CODE : S]

Ambient temperature: $-40...+65^{\circ}\text{C}$
Dampening liquid : Silicon oil

DIMENSIONAL DRAWINGS

DN 40 / DN 50 / DN 63

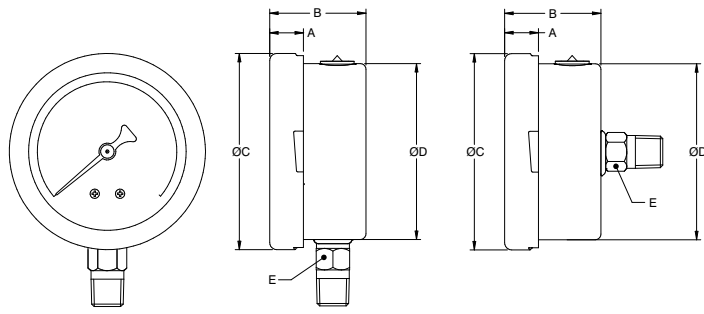

BD - Direct Bottom

BC - Center back

MOUNTING ACCESSORIES

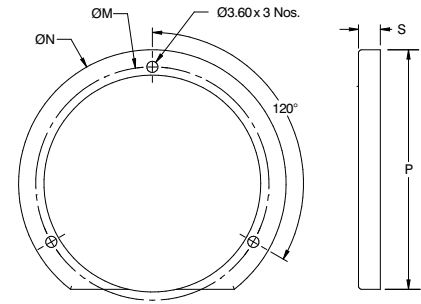

BF - BACK FLANGE

DN 80 / DN 100

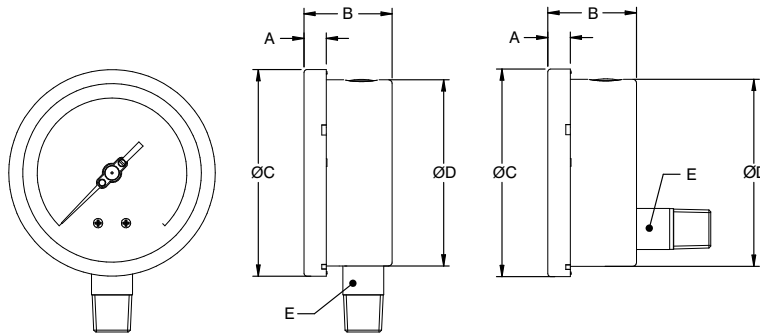

BD - Direct Bottom

BC - Center back

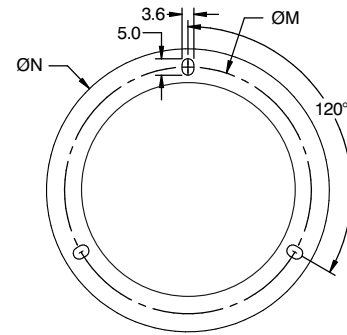

FF - FRONT FLANGE

NS	A	B	ØC	ØD	E
40	10	26.5	44	42	□ 12
50	10	29	53	52	□ 14
63	12	29	63	62	□ 14
80	12	35	78	76	□ 14
100	12	37	98.5	97	□ 17

All dimensions are in mm.

NS	P	S	ØN	ØM
63	77	7	86	75
100	128	7	134	118

All dimensions are in mm.

MODEL CODING

MODEL	-	DIAL SIZE	MOUNTING	CONNECTION	CASE EXECUTION	/	RANGE	/
133B = Open front, Case SS 304, Bourdon SS 316L 143B = Open front, Case SS 316, Bourdon SS 316L 134B = Open front, Case SS 304, Monel 400 144B = Open front, Case SS 316, Monel 400		15 = 40 mm 20 = 50 mm 25 = 63 mm 03 = 80 mm 04 = 100 mm	BD = Direct Bottom BC = Centre Back BL = Lower Back	M1N = 1/8" NPT (M) M1B = 1/8" BSP (M) M2N = 1/4" NPT (M) M2B = 1/4" BSP (M) M4N = 1/2" NPT (M) MBN = 1/2" BSP (M) M2M = M12 X 1.0P M4M = M20 X 1.5P M3B = 3/8" BSP (M)	D = Dry but fill-able G = Glycerin filled S = Silicon oil filled		0...10 to 0...15000 psi or 0...0.6 to 0...1000 bar or equivalent units	

OTHER OPTIONS		
BF = Back flange for bottom mounting FF = Front flange for lower back/center back mounting UC = "U" Clamp mounting for lower back mounting TA = 5 - point factory calibration certificate XA = Tag plate in SS 304	XP = Maximum Reading Pointer OR = Over range protection 1.5 of FSD RG = Receiver Gauge TC = Material test certificate, 3.1 TO = Certificate of De-greasing	XB = Tag plates in SS 316 XD = Custom Dial Design / Private labeling OS = Overload stop VS = Vacuum stop

ORDERING EXAMPLE 133B-25.BD.M2N.G/0-100psi/TA

QUICK ORDER DETAILS / FEEDBACKS